

UPDATED

**E-Z EXTENSION HOUSING BUSHING
REMOVER AND INSTALLER
PLUS AN OUTPUT SHAFT SUPPORT FIXTURE
-- ALL IN ONE TOOL --**

MODEL # AZ 2200

**GENERAL MOTORS: THM180, 180C, 200, 200C, 350, 350C, 375, 2004R, 700R4
FORD: C-4, C-5, AOD,AODE, 4R70W
CHRYSLER: TF 904-72 ON**

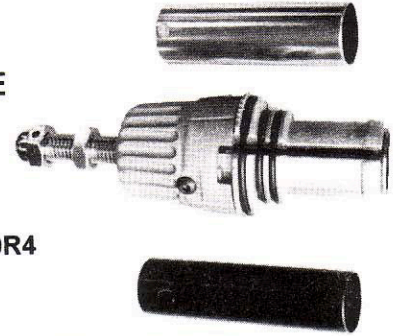

- E-Z REMOVAL AND INSTALLATION OF EXTENSION HOUSING BUSHINGS WHILE STILL IN THE CAR
- E-Z LOCKING FEATURE
- CENTERS AND HOLDS OUTPUT SHAFT IN PROPER POSITION FOR ASSEMBLY WORK
- TUBE EXPANDS SEGMENTS FOR E-Z REMOVAL OF BUSHING AND POSITIVE LOCATION OF REPLACEMENT BUSHING.
- GM AND MOST FORD USE BLACK TUBE, SILVER TUBE FOR CHRYLSEY, GOLD TUBE FOR FORD 4R70W

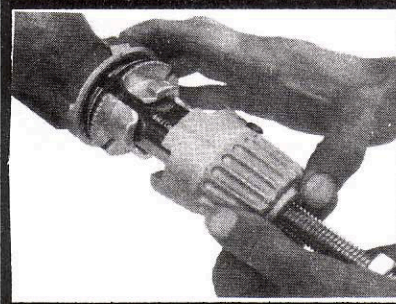

Slide expansion tube into segments and turn to lock position. Make sure lock pads are engaged.

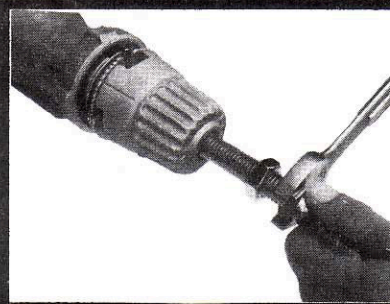

Turn bolt clockwise with 15/16" end wrench to remove bushing. **Do not use impact wrench!**

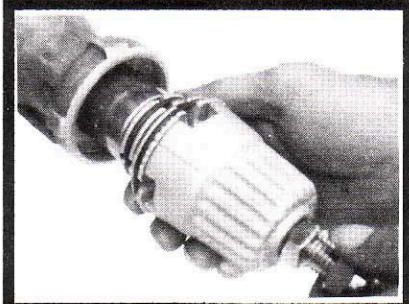

Tool removes bushing as a unit. Unlock cap and pull cap back to remove old bushing.

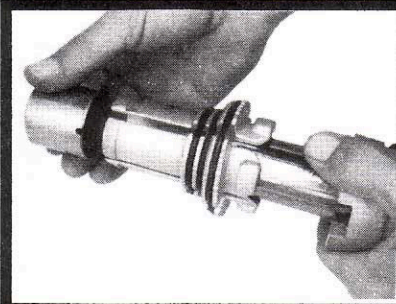

Place new bushing over segments. Remove bolt from cap. Return to lock position.

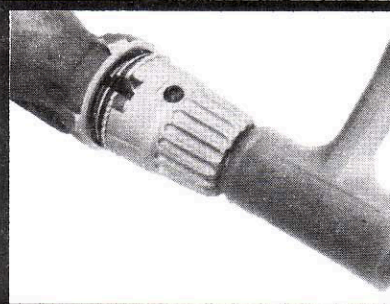

Drive in new bushing by hitting with plastic hammer or rubber mallet.



To use as A support fixture
Slide tube into segments and turn to lock position. Turn bolt to proper adjustment. Tighten lock nut.

PARTS LIST AND DIAGRAM:

- | | |
|---------------|--------------------------------|
| 1. AZ2200-1 | BOLT AND LOCK NUT (AS UNIT) |
| 2. AZ2200-2 | CAP AND SET SCREW (AS UNIT) |
| 2A. AZ2200-2A | SET SCREW, 1/8" HEX FEMALE |
| 3. AZ2200-3 | SEGMENTS AND O-RINGS (AS UNIT) |
| 4. AZ2200-4 | BLACK TUBE FOR FORD AND G.M. |
| 5. AZ2200-5 | SILVER TUBE FOR CHRYSLER |
| 6. AZ2200-6 | GOLD TUBE FOR FORD 4R70W |

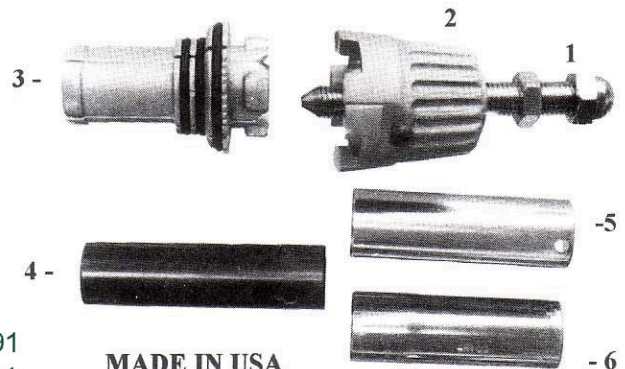

A to Z Tool, Inc.

144 W. Commercial St., Wood Dale, IL 60191
Phone: (630) 787-0478 Fax: (630) 787-0494

MADE IN USA